



Modelling of PMBLDC Motor and Study of Electromagnetic Characteristics

Dhananjaya B

Asst. Prof., Dept. of EEE
NMAMIT(NU), Nitte
Karkala, India

dhananjay.b@nitte.edu.in

Dr. Rajalakshmi Samaga

Professor, Dept. of EEE
NMAMIT(NU), Nitte
Karkala, India

raji.samaga@nitte.edu.in

Abstract

Electric vehicles are commercially developed with the intention of providing the range, pursuance, comfort to commuter, safety and hassle-free operation at a fair and vying price range. It has become very much essential for the automobile industries to install batteries performing at its best, available at low cost which are safe and reliable. Also, it is necessary to develop an interspersed propulsion system to provide large power density, enhanced efficiency which could be very critical for the future Electric vehicles. The present PMBLDC motors of 48V were employed in light vehicle applications which have disadvantages such as decreasing torque to speed ratio and decreasing power to speed ratio. The torque and power of PMBLDC motors were tending to remain constant after speed. The characteristic of the motor was studied using FEM. This work is proposed to build a 72V PMBLDC motor which will be replacing the existing 48V PMBLDC motor for Light Motor Vehicle applications. The power output of the motor will be comparatively high. It has been proposing to design a controller using INSTA-SPIN(BLDC) controller from Texas instruments which will be able to produce the required switching patterns from the 3-Phase bridge in order to regulate the Torque and power produced, when compared to the existing 48V PMBLDC. The characteristic of both the motors are to be compared using FEM. The torque vs speed curve is expected to remain constant with the increasing loads applied on the motor. The motor is expected to produce power constantly with the increasing loads.

Keywords: ICEV, EV's, PMBLDC, INSTA- SPIN, ZEV.

1.Introduction

The globe is looking at accelerated pace and high priority towards the concepts of energy management and environmental security through the research and the development in the field of electric vehicle technology. The long-term dreams of practical were sprouting to realize in 1990's.

The concept of Electric vehicles (EV's) was known and utilized by mankind since 1843. Apart from its use in domestic applications they even sold reasonably well in the commercial world till 1918. The EV's usage gradually started to decline due to enormous research and Improvement in the field of gasohol powered internal combustion engine (ICE). However, the EV's had very poor performance and efficiency and heavier on pockets than the Internal combustion engine counterparts. The edges which made the electric vehicles fail in its competition against ICE's are yet to be overcome to some extent. Recent developments in the field of Power Electronics, Microelectronics, Battery technology, Materials production technology have made the performance of EV's with ICE powertrains[1,2,3].

The momentous elements which stimulated the revitalization of EV's are Tariff and dependence of energy and protection of ecosystem. Due to the fore-coming crisis of fossil fuels and its by products, its cost and shortage of supply has propelled the man kind to investigate an alternate mode of transportation, possibly EV's. The source of energy for EV's can be mustered from various energy sources which are freely and abundantly available in nature and from power utilities, making them an extremely flexible fuel vehicle. The main reason behind the revival of EV's is environmental consideration as EV's are able to reduce air pollution in city traffic.

EV's can be more efficient in terms of energy in day-to-day traffic conditions, producing zero emission meeting the strategies laid down by National Energy strategy board such as future energy which is secure, efficient and non-hazardous to the environment.

The growing concern towards the deteriorating quality of air and emerging greenhouse consequence has pushed the government to enforce scrupulous actions against gasoline powered vehicles, pushing the EV's to the edge. All the developed countries globally are enforcing Zero Emission Vehicles (ZEV) quota. Hence, automobile industry has invested lot on the of research and development.

2.Objectives of Developing electric Vehicles

The perspective of EV's has drifted drastically during 90's; Popular automobile industries have floated combative curriculums and base programs to build EV's for commercial purpose, Government bureau and Educational institutions have Initiated intense R&D programs on EV's. The base developed EV performs better than the converted EV. The later one adopts

well to the state of art technologies. The disparity between the both are in terms of curb weight, Body style and system optimization techniques.

The initial investment on the EV's are about 3 times that on the gasoline power ICEV's. lowering the maintenance cost by about half of that of ICEV's. The thick line that separates the EV's from ICEV's are fuel cost and the efficiency. The developed countries spend an average of about 0.4-0.3 times the cost of fuels of ICEV's on EV's over 10000 to 25000 kms respectively. In EV's the cost of fuel per unit is inversely proportional to the mileage. The present practical maximum range of a battery pack which is charged once per day will be around 25000 kms.

The energy management system of the EV's are very carefully and critically designed to make sure that the energy is controlled, and flow is regulated from the batteries in a legitimate manner[2,3]. The chargers used for charging the batteries are made sure to be economical and charges the battery in the most economical and efficient manner. In most cases, the batteries are charged during night or by using dedicated quick chargers in a short period. EV's also utilise regenerative method to During braking to charge the batteries during braking period.

4.PMBLDC MOTOR

4.1 Determination of Characteristics of DC Motors

Electric Vehicle aims at building a successful merchandise over a protracted course catering performance, luxury, security and improved performance over extended period, luxury, security, seamless functionality alike internal combustion engine supplements at fair price[4,5,6]. All this turns out to be a dream come real when the EV's are supported by a high performing batteries and blended Electric train for propulsion.

The powertrain should exhibit constant torque characteristics for starting/climbing and shift to constant power characteristics during cruising for optimal performance. The previous works reveals heavy vehicles demand lesser torque, power and continuous speed. The downfall of EV's started in 1990s when the EV's couldn't meet the growing demands such as peak speed and performance with the oil fuelled engines in rural and urban roads. The emphasis for electric vehicle designers should be on the energy system and its effective management

This work concentrates on studying the possible characteristics of PMBLDC motor for its electromagnetic behaviour using FEM[6,7]. Based on the characteristics, PMBLDC motors are built with enormous power density suitable for Electric Vehicle applications.

The fields created by the distribution of magnetic and electrical energy are analysed using FEM. Finite Elements are the sub-domains that make up the analytical domain. The computation time is greatly reduced as the analysis is carried on field gradient, strength of magnetic field, saturation etc[8,9]. This analysis leads to very accurate results as it considers the air gap.

The Two-Dimensional structure of PMBLDC motor is drawn using AutoCAD to the specified dimensions. The 2-D figure is later Imported to FEMM software.

4.2 Graph of Magnetic field intensity vs length of selectedlines

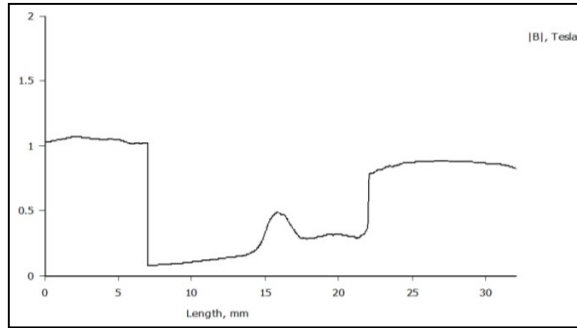

Fig.1. Plot of magnetic field intensity vs length of selected line

Fig.1. indicates the Magnetic field intensity plotted v/s length of selected line. The maximum field strength along the chosen line is represented by the peak value on the graph [10,11].

4.3 Graph of magnetic field density vs length of selected line

Fig.2. indicates the Magnetic flux density plotted vs length of selected line plot. The first peak signifies the magnetic flux density in the stator. The reduction in flux results from the conductive material cutting through the flux lines. The immediate peak represents the flux value in the air gap [12,13].

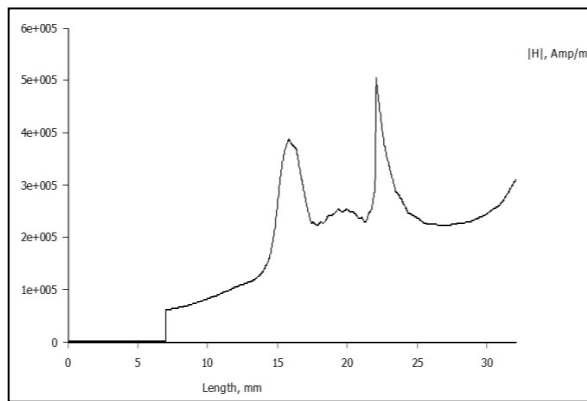

Fig.2. Plot of magnetic field density vs length of selected line

5. Mathematical Modelling of Electric Drive System for Vehicle

PMBLDC motor is connected to Three phase inverter which receives DC Supply and converts it into three phase AC supply

5.1 Mathematical Modelling of PMBLDC MOTOR

The PMBLDC motor is fed from the output of the inverter as it runs on AC input. Fig.3 indicates the equivalent circuit of the motor with the inverter output connected surface mounted PMBLDC motor. The literature survey proves that the frictional constant is very negligible, But

the present work takes the frictional constant into consideration and the same will be reflected in the transfer function derived below [14,15]. The motor is star connected. The frictional constant is considered in addition to the assumptions.

Assumptions:

- Inductance and resistance of the stator windings are equal
- Induced emf shapes of all three phases are same.
- Power electronic switches are ideal.
- Negligible iron losses.
- self and mutual inductance are constant.
- Armature reactions are negligible.
- The air gap is uniform
- Unsaturated motor.
- Zero power loss in the inverter

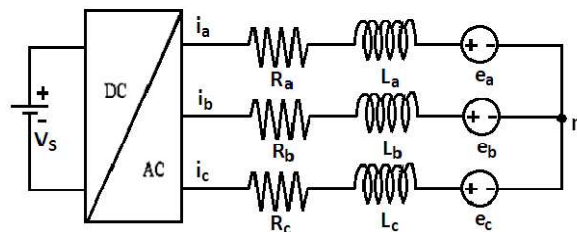

Fig.3. Equivalent circuit of three phase star connected inverter

The equation that governs the Model is given by

$$\begin{aligned} V_a &= V_N + V_{sA} \\ V_b &= V_N + V_{sB} \quad (1) \\ V_c &= V_N + V_{sC} \end{aligned}$$

V_{sA} , V_{sB} , V_{sC} are the output voltages of inverter that supply power to three phase winding of motor. V_A , V_B , V_C are the motor armature winding voltage. V_N is the voltage at the terminal.

The matrix-form equation that governs the voltage of the motor winding, for the symmetrical winding and balanced system is,

$$\begin{bmatrix} V_a \\ V_b \\ V_c \end{bmatrix} = \begin{bmatrix} R_a & 0 & 0 \\ 0 & R_b & 0 \\ 0 & 0 & R_c \end{bmatrix} \frac{di}{dt} \begin{bmatrix} L_a & L_{ab} & L_{ac} \\ L_{ba} & L_b & L_{bc} \\ L_{ca} & L_{cb} & L_c \end{bmatrix} \begin{bmatrix} i_a \\ i_b \\ i_c \end{bmatrix} + \begin{bmatrix} e_a \\ e_b \\ e_c \end{bmatrix} \quad (2)$$

This takes the form of

$$v_a = R_a i_a + \frac{d}{dt} L_a i_a + e_a \quad (3)$$

Considering $R_a = R_b = R_c = R$, the matrix of the resistance takes the form

$$R_a = \begin{bmatrix} R_a & 0 & 0 \\ 0 & R_b & 0 \\ 0 & 0 & R_c \end{bmatrix} \quad (4)$$

For the surface mounted permanent magnet motor with symmetrical winding, self-inductance and mutual inductance are constant [16,17]

$$L_a = L_b = L_c = L; L_{ab} = L_{bc} = L_{ba} = L_{cb} = L_{ac} = M \quad (5)$$

Thus, the matrix of inductance is,

$$L_a = \begin{bmatrix} L & M & M \\ M & L & M \\ M & M & L \end{bmatrix} \quad (6)$$

By KCL, for the stator winding connected in star, the sum total of current is zero

$$i_A + i_B + i_C = 0 \quad (7)$$

Now the equation takes the form

$$\begin{bmatrix} v_a \\ v_b \\ v_c \end{bmatrix} = i \begin{bmatrix} R_a & 0 & 0 \\ 0 & R_b & 0 \\ 0 & 0 & R_c \end{bmatrix} \frac{di}{dt} \begin{bmatrix} L_a & L_{ab} & L_{ac} \\ L_{ba} & L_b & L_{bc} \\ L_{ca} & L_{cb} & L_c \end{bmatrix} \begin{bmatrix} i_a \\ i_b \\ i_c \end{bmatrix} + \begin{bmatrix} e_a \\ e_b \\ e_c \end{bmatrix} \quad (8)$$

“e” is the instantaneous angle between a phase and rotor [18,19]. The fig.4. shows the position angle where phase A is taken as the reference to find e. With this reference axis the emf of phase A is

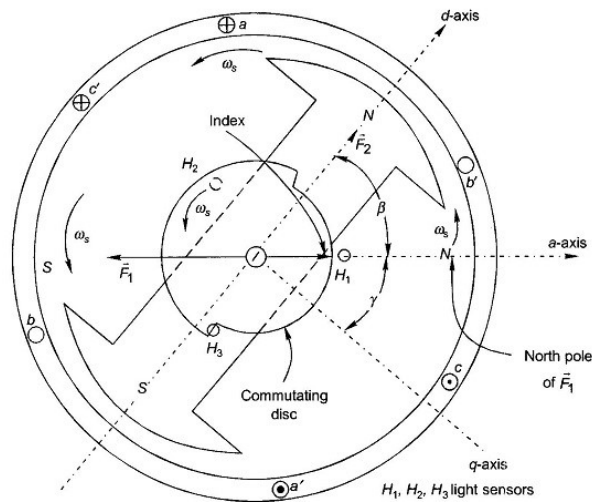

Fig.4. Rotor Position illustrations

$$E_a = \frac{k_e}{P} \begin{bmatrix} \sin \theta_e \\ \sin \left(\theta_e - \frac{2\pi}{3} \right) \\ \sin \left(\theta_e - \frac{4\pi}{3} \right) \end{bmatrix} \frac{d\theta_e}{dt} \quad (9)$$

For the power quality equation,

Input power = Output power for the inverter,

Thus, the input current to the inverter is given by,

$$i_{Sk} = \frac{(i_A v_{SA} - i_B v_{SB} - i_C v_{SC})}{v_s} \quad (10)$$

By the Newtons second law of motion, the general torque equation of the electric drive system is defined by Mechanical block shown in fig.5.

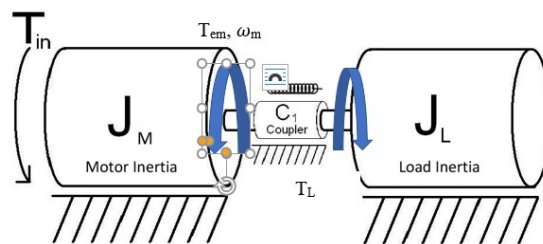

Fig.5. Mechanical system showing Torque, Moment of Inertia and Angular velocity

From the above mechanical block, we know that,

$$T_{eq} = J \frac{d}{dt} \omega_m + B \omega_m + T_L \quad (11)$$

Where ω_m is the speed, T_L is the load torque, T_{eq} is equivalent torque, B is the Frictional coefficient, J_{eq} is the equivalent moment of inertia.

The equation for the equivalent torque in relation with current, speed and emf is given by

$$T_{eq} = \frac{e_a I_a}{\omega_m} + \frac{e_b I_b}{\omega_m} + \frac{e_c I_c}{\omega_m} \quad (12)$$

$$= K_E (f_a(\phi_e) \cdot i_A + f_b(\phi_e) \cdot i_B + f_c(\phi_e) \cdot i_C) \quad (13)$$

Where, $f_a(\phi_e) = \sin \theta_e$, $f_b(\phi_e) = \sin \left(\theta_e - \frac{2\pi}{3} \right)$, $f_c(\phi_e) = \sin \left(\theta_e - \frac{4\pi}{3} \right)$

The equations that decide the state model of the system is,

$$\frac{d}{dt} i_a = \frac{(v_a - i_a R_a - E_a)}{L} \quad (14)$$

$$\frac{d}{dt} i_b = \frac{(v_b - i_b R_b - E_b)}{L} \quad (15)$$

$$\frac{d}{dt} i_c = \frac{(v_c - i_c R_c - E_c)}{L} \quad (16)$$

Hence the state model for the Permanent Magnet Brushless DC (PMBLDC) drive is given by,

$$\dot{x} = Ax + Bu$$

$$X = [i_a \quad i_b \quad i_c \quad \omega_r \quad \Theta_e]$$

$$B = \begin{bmatrix} \frac{1}{L_s} & 0 & 0 & 0 \\ 0 & \frac{1}{L_s} & 0 & 0 \\ 0 & 0 & \frac{1}{L_s} & 0 \\ 0 & 0 & 0 & -\frac{1}{J} \\ 0 & 0 & 0 & 0 \end{bmatrix}$$

$$u = [v_a \quad v_b \quad v_c \quad T_L]^t$$

The equivalent circuit for the PMSBLDC motor is like that of conventional DC motor shown in fig.6.

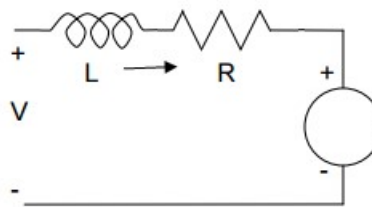

Fig.6. Per phase equivalent of DC Motor

By Kirchoff's Voltage law

$$V_s = Ri + L \frac{di}{dt} + e \quad (17)$$

$$A = \begin{bmatrix} -\frac{R_s}{L_s} & 0 & 0 & \frac{K_E(fa(\phi_e))}{L_s} & 0 \\ 0 & -\frac{R_s}{L_s} & 0 & \frac{K_E(fb(\phi_e))}{L_s} & 0 \\ 0 & 0 & -\frac{R_s}{L_s} & \frac{K_E(fc(\phi_e))}{L_s} & 0 \\ \frac{K_E(fa(\phi_e))}{J} & \frac{K_E(fb(\phi_e))}{J} & \frac{K_E(fc(\phi_e))}{J} & -\frac{D}{J} & 0 \\ 0 & 0 & 0 & \frac{P}{2} & 0 \end{bmatrix}$$

Re-arranging the equation yields,

$$e = -Ri - L \frac{di}{dt} + V_s \quad (18)$$

From torque equation,

$$T_e = K_f \omega_m + J \frac{d\omega_m}{dt} + T_L \quad (19)$$

The electric torque and back emf are given by,

$$e = K_e \omega_m$$

$$T_e = K_t I \quad (20)$$

Where, K_e and K_t are emf and torque constants

Re-arranging voltage equations and torque equation yields

$$\frac{di}{dt} = i \left[\frac{R}{L} - \frac{K_e}{L} \omega_m \right] + \frac{1}{L} V_s \quad (21)$$

$$\frac{d\omega_m}{dt} = -i \left[\frac{K_t}{J} - \frac{K_f}{J} \omega_m \right] + \frac{1}{J} T_L \quad (22)$$

Taking Laplace transform of equation

$$s i = -i \left[\frac{R}{L} - \frac{K_e}{L} \omega_m \right] + \frac{1}{L} V_s \quad (23)$$

$$s \omega_m = -i \left[\frac{K_t}{J} - \frac{K_f}{J} \omega_m \right] + \frac{1}{J} T_L \quad (24)$$

At No-load, Load torque will be zero

$$(T_L = 0)$$

$$i = \frac{s \omega_m + \frac{K_f \omega_m}{J}}{\frac{K_t}{J}} \quad (25)$$

Now substituting the value of equation, we get,

$$\left\{ \left(\frac{s^2 J}{K_t} + \frac{s^2 K_f}{K_t} + \frac{s R J}{K_t L} + \frac{K_f R}{K_t L} \right) + \frac{K_e}{L} \right\} \omega_m = \frac{1}{L} V_s \quad (26)$$

In the motor, the output is obtained in terms of rotational speed and the input to the motor is voltage, transfer function is the ratio of output to the input, Hence the transfer function of the motor is given by

$$G(s) = \frac{\omega_m}{V_s} = \frac{K_t}{s^2 J L + (R J + K_f L) s + K_f R + K_e K_f} \quad (27)$$

On simplification the transfer function of the PMBLDC Motor with the above given assumptions is

$$G(s) = \frac{\frac{1}{K_e}}{\tau_m \tau_e s^2 + \tau_m s + 1} \quad (28)$$

Where $\tau_m = \frac{3J R}{K_e K_t}$ and $\tau_e = \frac{L}{3R}$

For the block diagram reduction on re-arranging transfer function

$$G(S) = \frac{\frac{1}{sL+R} \cdot K_t \cdot \frac{1}{sJ+K_f}}{(sL+R)(sJ+K_f) + K_t K_e} \quad (29)$$

The diagram illustrates the block diagram of the BLDC motor in fig.7

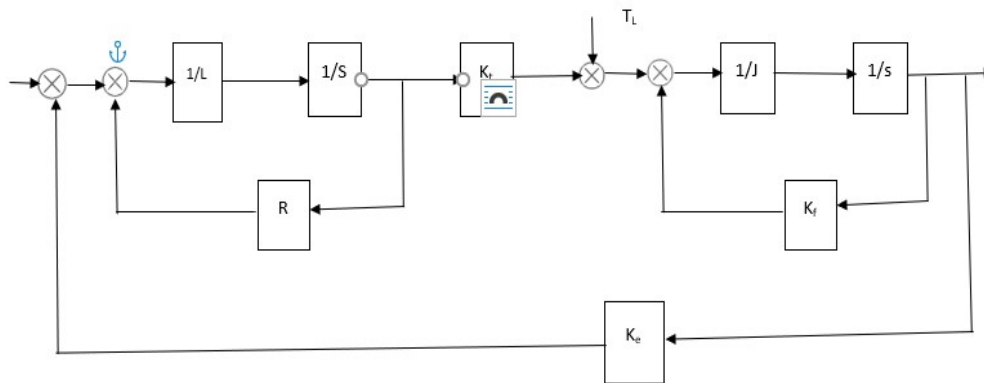

Fig.7. Block diagram of PMBLDC Motor

6.Results

The below graph shown in fig.8. represents the magnetic field intensity plotted against length of magnetic field intensity and fig.9. Magnetic flux density against length of selected line for a PMBLDC Motor with 2mm air gap

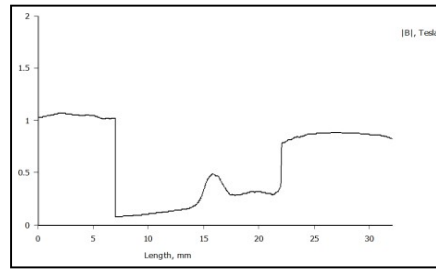

Fig.8.Magnetic field intensity Vsmagnetic field intensity

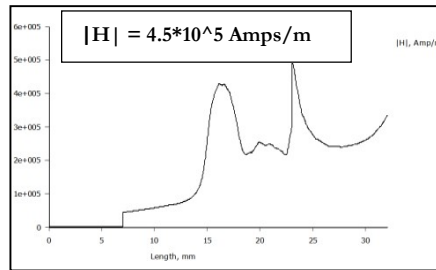

Fig.9.Magnetic flux Vsmagnetic field intensity

7.Conclusion

The model for the desired PMBLDC motor is obtained using the mathematical derivations with the standard assumptions. The block diagram for the same is obtained establishing the relationship between the mechanical and electrical models to suit the requirements. The graphs necessary for the foresaid application is also obtained and plotted proving that the PMBLDC motor has characteristics when compared to the other motors. However, the weight and space consumed will be a disadvantage which can be overcome in the coming future. The Battery discharge time will be more as compared with the previous systems which can be overcome by designing the controller in a proper fashion based on the requirements

Acknowledgement

All the authors who have contributed substantially have been working for academic institute and all the Authors listed have no conflict of interest relevant to this article.

REFERENCES

- [1] Xiaoli Sun, Zhengguo Li, Xiaolin Wang, Chengjiang Li, "Technology Development of Electric Vehicles: A Review", *www.mdpi.com/journal/energies*, *Energies* 2020, 13, 90; doi:10.3390/en13010090
- [2] Prakhyath Shetty; A. K. Nitin Subramonium; M. Sathyendra Kumar, "Mathematical Modeling of Permanent Magnet Brushless DC Motor for Electric Scooter", 2015 Fifth International Conference on Communication Systems and Network Technologies, DOI: 10.1109/CSNT.2015.110, © 2015
- [3] Pooja Naresh Bhatta, Hemant Mehar b, Manish Sahajwani, "Electrical Motors for Electric Vehicle – A Comparative Study", *International Conference on Recent Advances in Interdisciplinary Trends in Engineering & Applications (RAITEA) 2019*, SSRN-ELSEVIER (2018-2019)
- [4] Uma Gupta, "Research On Permanent Magnet BLDC for small electric vehicle", arXiv.org 27 May 2014
- [5] Szymon Racewicz, Paweł Kazimierczuk, "light two-wheeled electric vehicle energy balance investigation using chassis dynamometer", DOI 10.2478/ama-2020-0025
- [6] Bhim Singh, Sanjeev Singh, "State of art on Permanent magnet brushless dc motor drive", *Journal of power electronics*, vol.9, No.1, January 2009
- [7] Tae-Hyoung Kim, Sang-Hun Lee, Byung-Hun Yu, Jun-Young Park, Jae-Wan Moon "Design and analysis of low power traction motor for personal electric mobility system", *International Conference on Electrical Machines and Systems (ICEMS) 2013*, DOI: 10.1109/ICEMS.2013.6754417
- [8] C. Bharatiraja, Shyam Babu, V. Krishnakumar, P. Sanjeevikumar, Nixon George, "Investigation of Slim Type BLDC Motor Drive with Torque Ripple Minimization using Abridged Space-Vector PWM Control Method", *International Journal of power electronics and drive systems (IJPEDS)*, 2017, DOI: 10.11591/ijpeds.v8.i2.pp593-600.
- [9] Jinhe Zhou, Seyyedmilad Ebrahimi, Juri Jatskevich "Dynamic Performance Improvement of Brushless DC Motors Using a Hybrid MTPV/MTPA Control", *IEEE Electrical Power and Energy Conference (EPEC)*, DOI: 10.1109/EPEC52095.2021.9621734.
- [10] Gabriel Rodrigues Bruzinga, Alfeu Joãozinho Sguarezi Filho, Ademir Pelizari, "Analysis and Design of 3 kW Axial Flux Permanent Magnet Synchronous Motor for Electric Car", *IEEE Latin America transactions*, VOL. 20, NO. 5, MAY 2022.
- [11] Nishtha Shrivastava, Anil Brahmin, "Design of 3-Phase BLDC Motor for Electric Vehicle Application by Using Finite Element Simulation", *International Journal of Emerging Technology and Advanced Engineering*, (ISSN 2250-2459, ISO 9001:2008 Certified Journal, Volume 4, Issue 1, January 2014.
- [12] D. Vimalakeerthy, Dr. N. Kanagaraj, Dr. M. Y. Sanavullah, "Novel Design of Permanent Magnet Synchronous Reluctance Motor using Finite Element Method", *International Journal of Engineering Science and Innovative Technology (IJESIT)* Volume 2, Issue 1, January 2013.

- [13] Yung-kangChin,"A permanent magnet synchronous motor for an electric vehicle -design analysis", TRITA-ETS-2004-04,ISSN 1650-674x.
- [14]Harimohan Agarwal, Krishan Choudhary, Sushil Jangid, Ravi Sharma, Rohit Bansal,"Review Paper for Drives used in Electrical Vehicle (EV) and Hybrid Electrical Vehicles (HEV)", Trends in Machine Design,2020.
- [15] Kose, ErcanMuhurcu, Aydın,"The Control of Brushless DC Motor for Electric Vehicle by Using Chaotic Synchronization Method",Studies in Informatics and Control,Volume 27 Issue 4,doi:10.24846/v27i4y201804.
- [16] Mark Patrick,"How to Control Brushless DC Motors",EE power 2023.
- [17] Xiaoguang Xu, Miao Wang, Ping Xiao, Jiale Ding , Xiaoyu Zhang ,"In-Wheel Motor Control System for Four-Wheel Drive Electric Vehicle Based on CR-GWO-PID Control",www.mdpi.com/journal/sensors, doi.org/10.3390/s23198311.
- [18] Gaurav Nanda,NarayanKar,"A Survey and Comparison of Characteristics of Motor Drives Used in Electric Vehicles",Canadian Conference on Electrical and Computer Engineering,May 2006 DOI:10.1109/CCECE.2006.277736.
- [19] Manali P.Chavhan, PayalA.Shinde,"Modeling of Brushless DC Motor for Electric Vehicle Application", IOSR Journal of Engineering (IOSRJEN) ISSN (e): 2250-3021, ISSN (p): 2278-8719,Vol. 09, Issue 5 (May. 2019)